







varisco[®]
solid pumping solutions











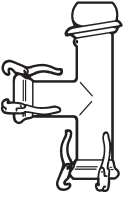

**Pribor za pumpe i
iglo filtere**
**Accessories for pumps and
wellpoint system**
**Accessoires pour pompes et
équipements wellpoint**
**Accesorios para bombas y
instalaciones wellpoint**

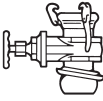

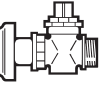



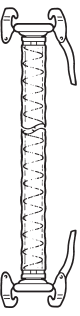
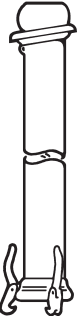
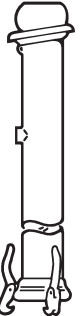

Opis Description Descripción	Image	Material Material Matériel Material	Napomena Notes Remarques Notas	Šifra Code Code Código	Težina Weight Poids Peso [kg]	Duljina Length Longueur Longitud [mm]	Promjer Diameter Diamètre Diámetro [mm / in]	Spojevi Connections Connexions Conexiones	
								[mm]	[in]
N° 1 Spojnica muška Male hose fitting Raccord mâle porte-tuyau Racor macho para manguera		Čelik pocinčano Galvanized steel Acier galvanisé Acero galvanizado		10013367	0,4	110	40	50	2"
				10013368	0,6	130	50	50	2"
				10013369	0,8	140	60	80	3"
				10013371	1,3	230	80	100	4"
				10013374	1,7	280	100	120	5"
				10013376	2,8	290	120	150	6"
				10013377	3,5	295	150	200	8"
				10013379	8	355	200	250	10"
				10013380	12	400	250	300	12"
				10013381	24	505	300	50	2"
				10013349	0,8	105	40	80	3"
				10013350	1,3	140	50	100	4"
N° 2 Spojnica ženska Female hose fitting Raccord femelle porte-tuyau Racor hembra para manguera		Čelik pocinčano Galvanized steel Acier galvanisé Acero galvanizado		10013351	1,4	150	60	80	3"
				10013354	1,5	225	80	100	4"
				10013357	2,0	240	80	120	5"
				10013356	2,3	250	100	150	6"
				10013359	3,0	255	120	200	8"
				10013360	3,6	260	150	250	10"
				10013363	9	300	200	300	12"
				10013365	11	340	250	50	2"
				10013366	25	440	300	80	3"
				10013311	0,3	60	1 ¼"	100	4"
				10013312	0,4	70	1 ½"	120	5"
				10013313	0,5	85	2"	150	6"
N° 3 Spojnica muška - navoj Threaded male coupling Raccord mâle fileté Racor macho roscado		Čelik pocinčano Galvanized steel Acier galvanisé Acero galvanizado		10013316	1,4	145	3"	80	3"
				10013318	1,9	150	4"	100	4"
				10013324	3,0	190	5"	120	5"
				10013326	3,5	170	5"	150	6"
				10018445	3,8	180	6"	50	2"
				10013302	0,7	75	1 ¼"	80	3"
				10013301	0,9	80	1 ½"	100	4"
				10013303	1	100	2"	120	5"
				10013304	1,7	110	3"	150	6"
				10013307	2,1	115	4"	80	3"
				10013308	3,2	125	5"	100	4"
				10013310	4	140	6"	120	5"
N° 4 Spojnica ženska - navoj Threaded female coupling Raccord femelle fileté Racor hembra roscado		Čelik pocinčano Galvanized steel Acier galvanisé Acero galvanizado		10013303	1	100	2"	80	3"
				10013304	1,7	110	3"	100	4"
				10013307	2,1	115	4"	120	5"
				10013308	3,2	125	5"	150	6"
				10013310	4	140	6"	50	2"

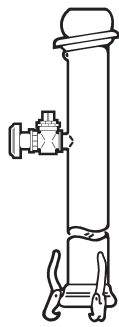
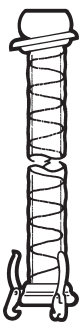

Opis Description Description Descripción	Image	Material Material Matériel Material	Napomena Notes Remarques Notas	Šifra Code Code Código	Težina Weight Poids Peso [kg]	Dujina Length Longueur Longitud [mm]	Promjer Diameter Diamètre Diámetro [mm / in]	Spojevi Connections Connexions Conexiones	
								[mm]	[in]
N° 5 Prikjučna spojnica - muška Flanged male coupling Raccord mâle bridé Racor de brida macho		Čelik pocinčano Galvanized steel Acier galvanisé Acero galvanizado	**EN 1092-1 PN 10/16 *Ø 150 sa pločom with cut avec couronne tronquée fresado	10013331	1,5	50		50	2"
				10013314	5	100		80	3"
				10013332	6	120		100	4"
				10013335	8	180			
				**10013336	10	205		150	6"
				*10013338	8	180			
				10013344	10	255		200	8"
				10013347	20	315		250	10"
				10013348	30	380		300	12"
				10013396	2,5			80	3"
N° 6 Koljeno45° 45° elbow Coudé 45° Curva 45°		Čelik pocinčano Galvanized steel Acier galvanisé Acero galvanizado		10013397	3,4			100	4"
				10013398	4,5			120	5"
				10013399	6			150	6"
				10013401	15			200	8"
				10013402	22			250	10"
				10013404	1,7			50	2"
				10013405	2,7		2 kopče / levers 2 leviers / palacas	80	3"
				10013407	4			100	4"
				10013409	7			120	5"
				10013410	7,5			150	6"
N° 7 Koljeno 90° 90° elbow Coudé 90° Curva 90°		Čelik pocinčano Galvanized steel Acier galvanisé Acero galvanizado	3 kopče / levers 3 leviers / palacas	10022355	16			200	8"
				10047781	24			250	10"
				10013419	42			300	12"
				10013462	1,4			100	4"
				10013463	2			120	5"
				10013464	2,9			150	6"
				10013465	7			200	8"
				10021960	11			250	10"
				10013455	0,3			50	2"
				10013457	1,4			100	4"
N° 8 Čep muški Male cap Bouchon mâle Tapón macho		Čelik pocinčano Galvanized steel Acier galvanisé Acero galvanizado		10013458	1,9			120	5"
				10013459	2,3			150	6"
				10013460	7			200	8"
				10021959	11			250	10"
				10013455	0,3			50	2"
				10013457	1,4			100	4"
				10013458	1,9			120	5"
				10013459	2,3			150	6"
				10013460	7			200	8"
				10021959	11			250	10"
N° 9 Čep ženski Female cap Bouchon femelle Tapón hembra		Čelik pocinčano Galvanized steel Acier galvanisé Acero galvanizado		10013455	0,3			50	2"
				10013457	1,4			100	4"
N° 10 Čep navojni / Threaded plug Bouchon fileté / Tapón roscado		Čelik pocinčano Galvanized steel Acier galvanisé Acero galvanizado		10002383	0,2			32	1 1/4"

Opis Description Descripción	Materijal Material Matériel Material	Napomena Notes Remarques Notas	Šifra Code Code Código	Težina Weight Poids Peso [kg]	Dujina Length Longueur Longitud [mm]	Promjer Diameter Diamètre Diámetro [mm / in]	Spojevi Connections Connexions Conexiones	
							[mm]	[in]
N° 11 Račva T - žens./žens./muška spoj. Female/female/male "T" fitting Raccord a "T" femelle/femelle/mâle Racor "T" hembra/hembra/macho			10013449	6,5			100	4"
			10013450	8			120	5"
			10013452	10			150	6"
			10013453	26			200	8"
			10013454	32			250	10"
N° 12 Adapter spojnica muška/muška Male/male inverter coupling Raccord inversion mâle/mâle Racor inversión macho/macho			10013422	1			50	2"
			10013424	2,2			100	4"
			10018441	3,4			120	5"
			10013425	4,5			150	6"
			10013426	1,3			50	2"
N° 13 Adapter spojnica ženska/ženska Female/female inverter coupling Raccord inversion femelle/femelle Racor inversión hembra/hembra			10013428	3,3			100	4"
			10013429	4			120	5"
			10013430	5			150	6"
			10013434	3,5			100	4"
			10013435	4,8			120	5"
N° 14 Redukcija muško/ženska Male/female reducer Raccord reducteur mâle/femelle Reducción macho/hembra			10013436	5,5			100	6"
			10013437	5,5			120	6"
			10018442	8			150	8"
			10018444	13			150	10"
			10013431	3,6			80	3"
N° 15 Nepovratni ventil muško/ženska sp. Male/female gate valve / Vanne mâle/femelle Válvula de compuerta macho/hembra			10013432	4,9			100	4"
			10013439	5,5			150	4"
			10013433	5,5			120	5"
			10013684	5,5			80	3"
			10016741	9			100	4"
N° 16 Brtva O- ring Joint Junta tórica			10013685	10			120	5"
			10018447	14			150	6"
			10013049	0,02			50	2"
			10013051	0,05			80	3"
			10013052	0,07			100	4"
N° 17 Spojni ventil / Cock assembly Robinet complet / Grifo completo			10013053	0,1			120	5"
			10013054	0,15			150	6"
			10013056	0,28			200	8"
			10013057	0,47			250	10"
			10013058	0,67			300	12"
			10013660	1,5			32	1 1/4"

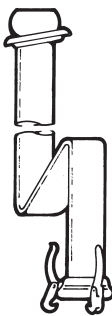

Opis Description Descripción	Opis Description Descripción	Materijal Material Matériel Material	Napomena Notes Remarques Notas	Šifra Code Code Código	Težina Weight Poids Peso [kg]	Duljina Length Longueur Longitud [m]	Spojivi Connections Connexions Conexiones [mm]	Spojivi Connections Connexions Conexiones [in]				
N° 18 Spojnica kutna / Elbow coupling Manchon courbe / Manguito curvo		Čelik pocinčano Galvanized steel Acier galvanisé Acero galvanizado		10013663	0,6	-	32	1 ¼"				
				10013687	2,5	1						
N° 19 Cijev iglofiltera / Riser pipe Tuyau de soulèvement / Tubo de elevación		Čelik pocinčano Galvanized steel Acier galvanisé Acero galvanizado		10013688	5	2						
				10013689	7,5	3						
				10013690	10	4						
				10013691	12,5	5						
				10013692	15	6						
				10013255	0,25	-	32	1 ¼"				
N° 20 Kupl. spojnica / Coupling sleeve Manchon / Manguito		Čelik / Steel Acier / Acero		10013255	0,25	-	32	1 ¼"				
				10013666	2,9	1	40	1 ½"				
				N° 22 Priključna cijev žen./žen. spoj Female/female Trasflex hose coupling Manchon Trasflex femelle/femelle Manguito Trasflex hembra/hembra		PVC	max usis Max vacuum Vide max Vacío max 10 m H ₂ O	10019262	9	4,0		
								10013470	11	5,8		
								10048925	12	6,2		
								10013473	12	4,0		
								10013474	16	5,8		
								10048926	17	6,2		
								10018448	15,5	4,0		
								10013477	21	5,8		
								10048927	22,5	6,2		
								10013480	16	3,0		
								10013478	21,5	4,0		
								10013479	29,5	5,8		
				N° 23 Odvodna cijev Discharge pipe Tuyau de refoulement Tubo de descarga		Čelik pocinčano Galvanized steel Acier galvanisé Acero galvanizado		10048928	32	6,3		
								10013481	44	4,0		
								10013482	59	5,8		
								10048929	63	6,3		
								10016773	66	4,0		
								10013483	90	5,8		
10048930	98	6,4										
10013485	80	4,0										
N° 24 Kolektor cijev sa otvorima Header pipe with threaded holes Tuyau collecteur avec prises pour robinet Colector con conexiones		Čelik pocinčano Galvanized steel Acier galvanisé Acero galvanizado	N° 3 - 1 ¼"	10013486	100	5,8						
				10048931	109	6,5						
				10018689	12	5,8	100	4"				
				10048936	13	6,2	120	5"				
				10013216	16,5	4,0	150	6"				
				10013219	22,5	4,0	100	4"				
				10051209	18,0	5,8	120	5"				
				10051211	19,0	6,2	150	6"				
				10013217	22,5	5,8	120	5"				
				10013220	32	5,8	150	6"				
				10048934	24	6,2	120	5"				
				10048935	33	6,3	150	6"				

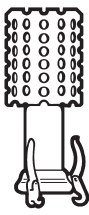
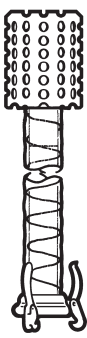
Opis Description Descripción	Opis Description Descripción	Materijal Material Matériel Material	Napomena Notes Remarques Notas	Šifra Code Code Código	Težina Weight Poids Peso [kg]	Duljina Length Longueur Longitud [m]	Spojevi Connections Connexions Conexiones [mm]									
N° 25 Kolektor cijev sa spojnicama Header pipe complete with cock assemblies Tuyau collecteur avec robinets Colector con grifos completos		Čelik pocinčano Galvanized steel Acier galvanisé Acero galvanizado	N° 3 - 1 ¼" N° 6 - 1 ¼" N° 3 - 1 ¼" N° 4 - 1 ¼" N° 6 - 1 ¼" N° 3 - 1 ¼" N° 4 - 1 ¼" N° 6 - 1 ¼"	10018691 10048941 10051210 10051212 10013654 10018449 10048940 10013655 10048937 10013657 10016162 10048939 10013658 10048938	16,5 17,5 24,0 25,0 21 28,5 30 31,5 33 27 38 39 41 42	5,8 6,2 5,8 6,2 4,0 5,8 6,2 5,8 6,2 4,0 5,8 6,3 5,8 6,3	100 100 120 150	4" 4" 5" 6" 6" 6" 6" 2" 2" 3" 4" 5" 6" 8" 10" 12"								
				N° 26 Fleks. cijev (PVC + spiralna armatura) Flexible hose (PVC with steel spiral) Tuyau flexible (PVC avec spirale d'acier) Tubo flexible (PVC con espiral de acero)		PVC	Max usis Max vacuum Vide max Vacío max [m H ₂ O]	10013539 10013540 10013541 10013549 10013550 10013551 10013552 10013561 10013563 10013564 10013565 10015784	9,5 12,5 18 9 17 19,5 23 53 22 26 30 10	4 6 10 2 4 5 6 2 4 5 6 10	50 80 100	2" 3" 4" 5" 6" 8" 10" 12"				
								N° 28 Fleks cijev (guma + spiralna armatura) tela con spirale in acciaio) Flexible hose (Rubber / canvas with steel spiral) Tuyau flexible (Caoutchouc/toile avec spirale d'acier) Tubo flexible (Caucho / tela con espiral de acero)		Guma / tela Rubber / canvas Caoutchouc / toile Caucho / tela	Max usis Max vacuum Vide max Vacío max [m H ₂ O]	10013570 10013572 10013571 10018452 10013573 10013580 10013575 10013576 10013577 10013581 10013582 10018460 10013583 10013585 10016001 10013586 10013587 10013588 10013591 10018811 10013592	16,5 20 27 38,5 22,5 29,5 39 47,5 55 42 67 79 92 64 77 103 124 153 75 112,5 150	2 3 4 6 2 3 4 5 6 2 3 4 5 6 2 3 4 5 6 2 3 4	120 150 200 250 300	5" 6" 8" 10" 12"

Opis Description Descripción	Materijal Material Matériel Material	Napomena Notes Remarques Notas	Šifra Code Código	Težina Weight Poids Peso	Duljina Length Longueur Longitud	Pritisak Pressure Pression Presión	Spojevi Connections Conexiones	
							[mm]	[in]
N° 29 Savijljiva odvodna cijev Flat discharge hose Tuyau de refoulement Manguera de descarga			10012918	0,32/m		8	40	1 ½"
			10012919	0,41/m		10	50	2"
			10012920	0,56/m		8	60	2 ½"
			10012921	0,77/m		8	80	3"
			10012922	1,05/m		8	100	4"
			10012923	1,28/m		6	127	5"
			10012924	1,60/m		4	150	6"
			10012925	2,40/m		2,5	204	8"
			10012926	1,30/m		5	250	10"
			10012927	2,10/m		5	300	12"
N° 30 Savijljiva odvodna cijev sa žen. sp. Flat discharge hose with female coupling Tuyau de refoulement avec raccord femelle Manguera de descarga con racor hembra			10013597	4,3	10	10	40	1 ½"
			10018651	7,5	10	10	50	2"
			10013606	9	10	10	80	3"
			10013611	11	10	10	100	4"
			10018652	14	10	6	127	5"
			10015378	23,5	10	4	150	6"
			10015399	28	10	2,5	204	8"
			10018653	39,5	10	5	250	10"
			10018654	76	10	5	300	12"
			10013620	5,5	10	8	40	1 ½"
N° 31 Savijljiva odvodna cijev muško/ženska spojnica Flat discharge hose with male/female couplings Tuyau de refoulement avec raccords mâle/femelle Manguera de descarga con racores macho/hembra			10013621	8	10	10	50	2"
			10013623	8	10	16		
			10013631	11,5	10	8	80	3"
			10013638	14,5	10	8	100	4"
			10013637	15	10	8		
			10018317	18	10	6	127	5"
			10013648	23	10	4	150	6"
			10013653	41	10	2,5	204	8"
			10013590	64	10	5	250	10"
			10013593	168	10	5	300	12"
N° 31.1 Savijljiva odvodna cijev muško/ ženska spojnica Jetting hose with male/female couplings Tuyau de lançage avec raccords mâle/femelle Manguera hincado con racores macho/hembra			10018699	11	10	10	50	2"

Opis Description Description	Material Matériel Material	Napomena Notes Remarques Notas	Šifra Code Código	Težina Weight Poids Peso	Dujina Length Longueur Longitud	Spojevi Connections Connexions Conexiones				
						[mm]	[in]			
N° 32 Usisni koš Strainer Crépine Filtro de fondo	Čelik pocinčano Galvanized steel Acier galvanisé Acero galvanizado		10013242	0,67	0,200	40	1 ½"			
			10013243	0,95	0,240	50	2"			
			10013246	1,95	0,320	80	3"			
			10013247	2,87	0,440	100	4"			
			10013248	4,5	0,550	120	5"			
			10013249	8	0,640	150	6"			
			10013252	15,5	0,810	200	8"			
			10013227	1,7	0,210	50	2"			
			10013228	2,8	0,320	80	3"			
			10013229	5	0,450	100	4"			
			10013230	7,5	0,610	120	5"			
			10013231	10,5	0,700	150	6"			
N° 33 Usisni koš sa ž spojnicom Strainer with female coupling Crépine avec raccord femelle Filtro de fondo con racor'hembra	Čelik pocinčano Galvanized steel Acier galvanisé Acero galvanizado		10013234	22	0,910	200	8"			
			10013235	90	1,190	250	10"			
			10013237	140	1,840	300	12"			
			10013495	9,5	4					
			10013496	11	6					
			10013497	12,5	6					
			10013503	15	6					
			10013506	17,5	4					
			10013507	20,5	5					
			10013508	24	6					
			10013520	22,5	4					
			10013521	26,5	5					
10013522	31	6								
N° 34 Fleks. cijev sa usis. košem (PVC sa spiralnom armaturom) Flexible suction hose with strainer (PVC with steel spiral) Tuyau flexible d'aspiration avec crépine (PVC avec spire d'acier) Tubo de aspiración flexible con filtro (PVC con espiral de acero)	PVC + Čelik poc. PVC + Galvanized steel PVC + Acier galvanisé PVC + Acero galvanizado		10017849	30	4	120	5"			
			10015729	38	6					
			10013530	28	2					
			10029782	30	3					
			10013529	44	4					
			10013527	52	5					
			10013528	60	6					
			10013534	73,5	4					
			10013535	99,5	6					
			N° 35 Fleks. cijev sa usis. košem (guma sa spiralnom armaturom) Flexible suction hose with strainer (Rubber / canvas with steel spiral) Tuyau flexible d'aspiration avec crépine (Caoutchouc/toile avec spire d'acier) Tubo de aspiración flexible con filtro (Caucho / tela con espiral de acero)	Guma + Čelik. pocin. Rubber / canvas + Galvanized steel Caoutchouc / toile + Acier galvanisé Caucho / tela + Acero galvanizado		10017849	30	4	120	5"
						10015729	38	6		
						10013530	28	2		
10029782	30	3								
10013529	44	4								
10013527	52	5								
10013528	60	6								
10013534	73,5	4								
10013535	99,5	6								
N° 37 Filter (tijelo aluminij, filter inox čelik) Wellpoint spear (aluminium frame, reps stainless steel screen) Pointe filtrante (châssis en aluminium, gaine filtrante en acier inox reps) Punta de filtración (bastidor de aluminio, vaina de filtración inoxidable reps)	Aluminij + Inox Aluminium + Stainless steel Aluminium + Acier inoxydable Aluminio + Acero inoxidable					10013671	1,7	0,650	32	1 ¼"

Opis Description Descripción	Image	Material Matériel Material	Napomena Notes Remarques Notas	Šifra Code Code Código	Težina Weight Poids Peso [kg]	Duljina Length Longueur Longitud [m]	Spojevi Connections Connexions Conexiones	
							[mm]	[in]
N° 39 Filter za šijunak Wellpoint spear for gravel Pointe filtrante pour gravillon Punta de filtración para gravilla		Aluminij Aluminium Aluminio		10013682	1,7	0,350	32	1 ¼"
N° 44 Cijev iglo-filtera sa filterom (Rif. 37) Riser pipe + wellpoint spear (Ref. 37) Tuyau de soulèvement + pointe filtrante (Réf. 37) Tubo de elevación + punta de filtración (Ref. 37)		Aluminij+čelik Aluminium + Steel Aluminium + Acier Aluminio + Acero		10013680	10	3	32	1 ¼"
				10013681	12,5	4		
				10018701	15	5		
				10017024	17,5	6		
N° 45 Cijev iglo-filtera sa filterom za šijunak Riser pipe + wellpoint spear for gravel Tuyau de soulèvement + pointe filtrante pour gravillon Tubo de elevación + punta de filtración para gravilla		Aluminij + čelik Aluminium + Steel Aluminium + Acier Aluminio + Acero		10016932	10	3	32	1 ¼"
				10016798	12,5	4		
				10013683	15	5		
				10018669	17,5	6		
N° 46 Cijev iglo-filtera Riser pipe Tuyau de soulèvement Tubo de elevación		PVC		10045490	3	2	32	1 ¼"
				10045491	4,5	3		
				10045492	5,5	4		
				10045493	7	5		
N° 47 Cijev iglo-filtera sa spojinicom Riser pipe with elbow Tuyau de soulèvement avec coude Tubo de elevación con codo		PVC		10045226	3	2	32	1 ¼"
				10045225	4	3		
				10044480	5	4		
				10044479	6,5	5		
N° 48 Filter / Wellpoint spear Pointe filtrante / Punta de filtración		PVC + PE HD		10044478	0,7	-	32	1 ¼"
				10045224	3,4	2		
				10045223	4,6	3		
				10044483	6	4		
N° 49 Cijev iglo-filtera sa spojinicom Riser pipe with elbow and wellpoint spear Tuyau de soulèvement avec coude et pointe filtrante Tubo de elevación con codo y punta de filtración		PVC + PE HD		10044482	7	5	32	1 ¼"
				10044484	8,5	6		

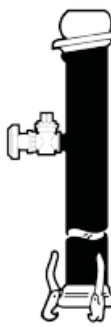
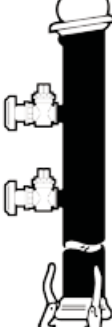
Opis Description Descripción	Opis Description Descripción	Materijal Material Matériel Material	Napomena Notes Remarques Notas	Šifra Code Código	Težina Weight Poids Peso [Kg]	Dujina Length Longueur Longitud [m]	Spojevi Connections Conexiones Conexiones	
							[mm]	[in]
N° 50 Izlazna cijev sa spojnicama Discharge pipe with couplings Tuyau de refoulement avec raccords Tubo de descarga con racores		PE HD		10045076	10	3,0	100	4"
				10045075	12	4,0	100	4"
				10045074	16	5,8	100	4"
				10045236	12,5	4,0	120	5"
				10045237	15,5	5,8	120	5"
				10045238	18,5	4,0	150	6"
N° 51 Kolektor cijev sa 3 otvora i spojnicama Header pipe with 3 threaded holes Tuyau collecteur avec 3 prises pour robinet Colector con 3 conexiones		PE HD	N° 3 - 1 1/4"	10044487	6,5	5,8	100	4"
				10045241	10,5	4,0	120	5"
				10045242	17	4,0	150	6"
N° 52 Kolektor cijev sa 6 otvora i spojnicama Header pipe with 6 threaded holes Tuyau collecteur avec 6 prises pour robinet Colector con 6 conexiones		PE HD	N° 6 - 1 1/4"	10044486	17,5	5,8	120	5"
				10044485	27,5	5,8	150	6"
N° 53 Kolektor cijev sa 3 spojna ventila. Header pipe with 3 cock assemblies Tuyau collecteur avec 3 robinets Colector con 3 grifos		PE HD	N° 3 - 1 1/4"	10044488	10	5,8	100	4"
				10045245	15	4,0	120	5"
				10045246	21	4,0	150	6"
N° 54 Kolektor cijev sa 6 spojinih ventila. Header pipe with 6 cock assemblies Tuyau collecteur avec 6 robinets Colector con 6 grifos		PE HD	N° 6 - 1 1/4"	10044489	25	5,8	120	5"
				10044490	33	5,8	150	6"

STANDARDNI PRIBOR ZA PUMPU

/ STANDARD PUMP ACCESSORIES / ACCESORIOS ESTÁNDARES PARA BOMBAS

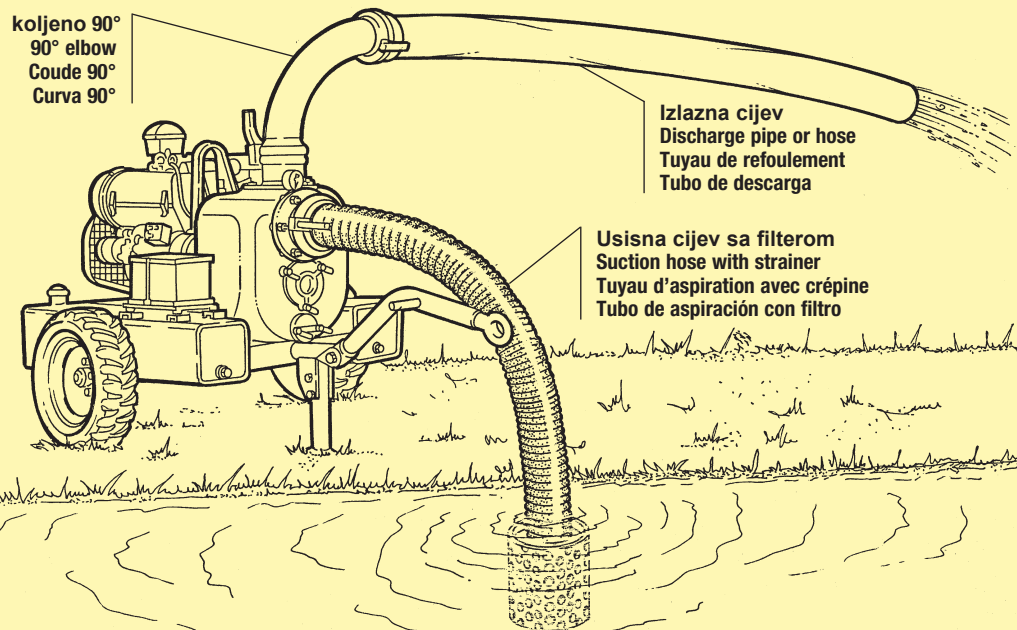

PRIBOR - SISTEM IGLO FILTERA

ÉQUIPEMENT WELLPOINT DE SÉRIE / STANDARD WELLPOINT SYSTEM

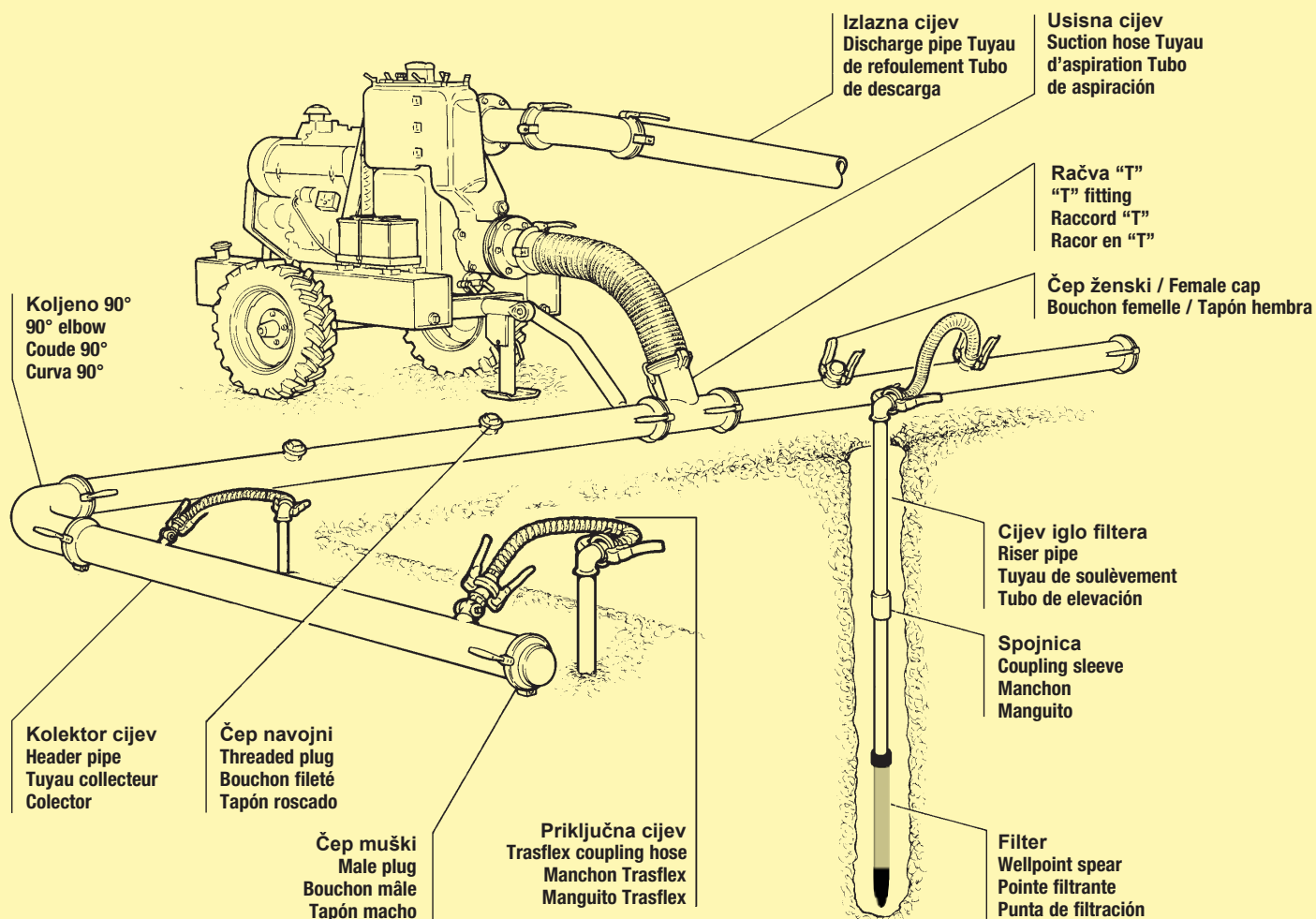



EN ISO 9001 : 2008
Reg. No. 44 100 091767



Possum doo, Selčica 18 - Orešje, 10434 Strmec Samoborski
Tel. +385 1 3776 524 - Fax +385 1 3756 360 - possum@possum.hr www.possum.hr